

GEMAC

USER MANUAL PRELIMINARY

Version: 1.0
Date: 10/07/2024



GEMAC MOTUS[®] GREENLINE NE ANALOG

NE1XP360-I

NE2XP090-I

NE1XP360-U

NE2XP090-U

REVISION HISTORY

Date	Revision	Change(s)
10/07/24	1.0	First version

© Copyright 2024 GEMAC Chemnitz GmbH

This document is subject to change without notice.
We constantly work to develop our products further. We reserve any changes in the scope of delivery in shape, equipment, and technology for ourselves. No claims can be made from the details, illustrations, and descriptions in this document. Any kind of duplication, reprocessing, and translation of this document, as well as excerpts from it, require the written permission of GEMAC Chemnitz GmbH. All rights, according to the copyright, remain explicitly reserved for GEMAC Chemnitz GmbH.

TABLE OF CONTENTS

1	Safety information	1
1.1	Incoming inspection	1
1.2	Intended use	1
1.3	Incorrect use	1
1.4	Requirements for the qualification of personnel.....	1
2	Overview	2
2.1	Characteristics.....	2
2.2	Applications	2
3	Technical Data	3
4	Orientation of the measuring axes	5
5	Mounting.....	6
5.1	Fixation	6
5.2	Arrangement of the fastening holes and position of the system edge	7
6	Connection.....	8
6.1	General connection information	8
6.2	Connector Pin Out	8
6.3	Internal circuit.....	8
6.4	Cable length and minimum supply voltage for current interface.....	9
7	Functional description.....	10
7.1	Default settings	10
7.2	Axis assignment / Reversal of direction / Range of measuring and output	10
7.3	Zero Point Adjustment	10
7.4	Low pass filter	10
7.5	Sensor fusion filter	12
8	Maintenance and Service	13
8.1	Calibration	13
8.2	Customer service	13
8.2.1	Reshipment.....	13
8.2.2	Support.....	13
8.2.3	Warranty and limitation of liability	13
9	Sensor configuration.....	14
9.1	Inclination sensor programming adapter.....	14

9.2	PC software ISDControl	14
10	Ordering information	16

LIST OF TABLES

Table 1: Technical Data 4

Table 2: M12 Plug Connector Pin Out 8

Table 3: Default output mapping..... 10

Table 4: Default settings of device parameters 10

Table 5: Filter selection low pass filter 11

Table 6: Filter selection fusion filter 12

Table 7: Ordering information 16

LIST OF FIGURES

- Figure 1: Orientation of the measuring axis 1-dimensional 5
- Figure 2: Orientation of the measuring axes 2-dimensional (factory default settings) 5
- Figure 3: Mounting holes 4-hole variant (dimensions in mm)..... 6
- Figure 4: Arrangement of the fastening holes and position of the system edge 7
- Figure 5: Connection diagram: current interface 8
- Figure 6: Connection diagram: voltage interface..... 8
- Figure 7: Cable length at current interface 9
- Figure 8: Impulse response of the two low pass filters11
- Figure 9: Amplitude response of the two low pass filters11
- Figure 10: Sensor programming adapter 14
- Figure 11: PC software 15

1 Safety information

1.1 Incoming inspection

Unpack the device immediately after you received it and check the entire delivery for completeness. If transport damage is to be assumed, inform the delivery agent within 72 hours, and keep the packaging for inspection. The device must only be transported in its original or equivalent packaging.

1.2 Intended use

The GEMAC MOTUS® Greenline NE is a device consisting of an electronic sensor and an integrated evaluation unit. The device is designed to determine inclinations in non-road mobile machinery or means of transport for persons or goods like agricultural and forestry machinery, utility vehicles or crane and hoisting technology.

GEMAC Chemnitz GmbH assumes no liability for losses or damages arising from the use of the product, either directly or indirectly. This applies in particular to use of the product that does not conform to this in-tended purpose and is not described in this document.

1.3 Incorrect use

The GEMAC MOTUS® Greenline NE is not a safety component according to the EC Machinery Directive (2006/42/EC) or the EU Machinery Regulation (2023/1230). It must not be used in explosion hazardous areas. It is not intended to be used in electronic vehicles with Rechargeable Energy Storage Systems (REESS) charging mode coupled to the power grid. Any use that is not described in section 1.2 „Intended use“ is prohibited. Any use of accessories that is not specifically approved by GEMAC Chemnitz GmbH is at your own risk.

1.4 Requirements for the qualification of personnel

The personnel who work on and with the GEMAC MOTUS® Greenline NE must be suitably authorized, trained, and sufficiently qualified. Skilled personnel refers to the following:

- Has received specialist training, which is backed up by additional knowledge and experience according to operation and service of the sensor and the respective application.
- Knows the relevant technical terms and regulations.
- Can appraise the work assigned to them, recognize potential hazards, and take suitable safety precautions.

2 Overview

2.1 Characteristics

- Dynamic inclination sensor
 - Accuracy independent of the local gravity field through 3D measurement
- Easy to handle parametrization with GEMAC programming tools
 - Intelligent sensor fusion algorithm, configurable for the application
 - configurable filter for vibration suppression
- High sampling rate and bandwidth
- High static accuracy independent of sensors orientation up to $\pm 0.5^\circ$
 - Specification including compensated cross sensitivity
- Dynamic accuracy model-dependent up to $\pm 0.8^\circ$
 - Specification including compensated cross sensitivity
- Comfortable current and voltage interface
- UV-resistant, impact-resistant plastic housing
- Suitable for industrial use:
 - Working temperature range: $-40\text{ }^\circ\text{C}$ to $+80\text{ }^\circ\text{C}$
 - Degree of protection: IP6K6K and IP6K7

The sensor is factory calibrated in all measuring axes to ensure high accuracy.

The compact and robust design makes the sensors a suitable angle measurement device in rough surroundings for different applications in industry and vehicle technology. Occurring accelerations caused by e.g. brake applications or cornering events are reliably filtered by an integrated fusion algorithm.

A simple configuration and putting into operation is possible by the digital interface.

2.2 Applications

- Agricultural and forestry machinery
- Construction machinery
- Crane and hoisting technology

3 Technical Data

General parameters ¹		
Measurement range	±90° (2-dimensional) or ±180° (1-dimensional)	
Resolution	min. 0.01° (depending on measuring range, output 12bit)	
Static accuracy (including cross sensitivity)	±0.5°	
Dynamic accuracy (including cross sensitivity)	typ ±0.8°	
Duration of suppression of external accelerations (configurable)	100 - 10000 ms	
Temperature coefficient (zero point)	typ. ±0.02 %/K	
Sampling rate	200 Hz	
Operating temperature	-40 °C to +80 °C ²	
Characteristics		
Current interface	NExxPxx0-I	NExxPxx0-U
	freely adjustable output in the range 0.4 ... 20 mA max. load resistance 900 Ω (@24V)	freely adjustable output in the range 0 ... 10 V
Functions	Teach input for zero point adjustment when installed. Full scale value limit, Axis direction and assignment of the outputs are adjustable. Digital low pass filter (critically damped or Butterworth, 8th order), Sensor fusion filter	
Elektrical parameters		
Supply voltage	11 ... 30 VDC	
Current consumption	approx. 30 mA @ 24 V (NExxPxx0-I: depending on the output current up to 70 mA @ 24 V)	
Mechanical parameters		
Connection	approx. 0.2 m cable with sensor connector 5-pole M12 (male)	
Degree of protection	IP6K6K / IP6K7	
Dimensions / Weight	4-hole variant: 62 x 32.3 x 18.7 mm (without cable) / approx. 30 g without cable 2-hole variant: 43.5 x 76.3 x 18.7 mm (without cable) / approx. 30 g without cable	
Reliability according EN ISO 13849-1 ³		
	NExxPxx0-I	NExxPxx0-U
MTTF	483 years	591 years
MTTFd	1201 years	1097 years
CE conformity		
European Union harmonisation legislation		
Directive 2014/30/EU	Harmonisation of the laws of the Member States relating to electromagnetic compatibility	

¹ All indicated angle accuracies are valid after a running time of 10 minutes at 25 °C, absolute calibration accuracy (at 25 °C): ±0.05°.

² The maximum temperature range of 80 °C is only valid for the NExxPxx0-I sensors with a minimum load resistance of 250 Ω and a maximum output current of 20 mA

³ This product is a standard product and no safety part in accordance with the machinery directive or regulation. The calculation is based on an average environment temperature of 40 °C and a usage of 8760 h/a.

Directive 2011/65/EU	Restriction of the use of certain hazardous substances in electrical and electronic equipment
Harmonised standards	
EN ISO 13766-1:2018 ⁴	Earth-moving machinery and construction machinery - Electromagnetic compatibility of machinery with internal electrical system - Part 1: General EMC requirements under typical EMC environmental conditions (ISO 13766-1:2018)
EN IEC 63000:2018	Technical documentation for the assessment of electrical and electronic products with respect to the restriction of hazardous substances

Table 1: Technical Data

⁴ A voltage limitation of the load shedding of 58 V is assumed (see ISO 16750-2:2012 Figure 9). The sensor must not be active during the starting phase of the vehicle and be used for providing convenience only.

4 Orientation of the measuring axes

The sensor is delivered with the measuring axes orientation shown in Figure 1 respectively Figure 2.



Figure 1: Orientation of the measuring axis 1-dimensional

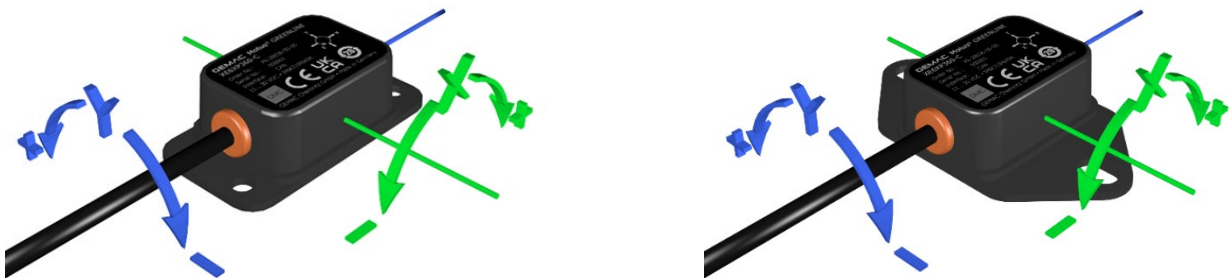

Figure 2: Orientation of the measuring axes 2-dimensional (factory default settings)

5 Mounting

5.1 Fixation

A sensor in the 4-hole version (NExXP360-x) must be screwed with four hexagon socket screws M4 according to DIN 912 A2 and four hexagon nuts M4 according to DIN 934. A sensor in the 2-hole variant (NExZP360-x) must be screwed with two hexagon socket screws M5 according to DIN 912 A2 and two hexagon nuts according to DIN 934.

Screws and nuts must be screwed with a torque of 3 Nm in a manner, that one full thread of the screw is overlapping minimum.

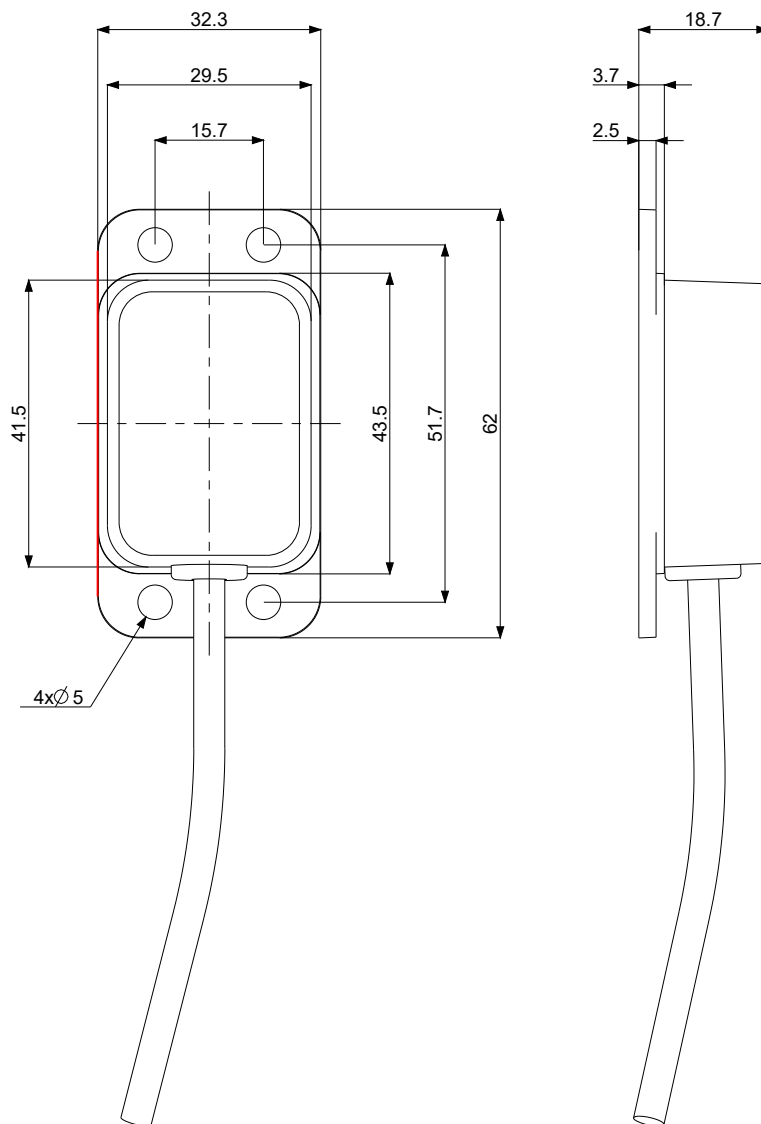

Figure 3: Mounting holes 4-hole variant (dimensions in mm)

5.2 Arrangement of the fastening holes and position of the system edge

The holes for screwing the sensor (Figure 3 and Figure 4) are located in the base plate of the sensor.

The bearing edge is marked in red in the illustrations. The measuring axes of the sensor are aligned parallel or orthogonal to this edge. For more information on the reference edge, see [gemac-sensors.com](https://www.gemac-sensors.com).

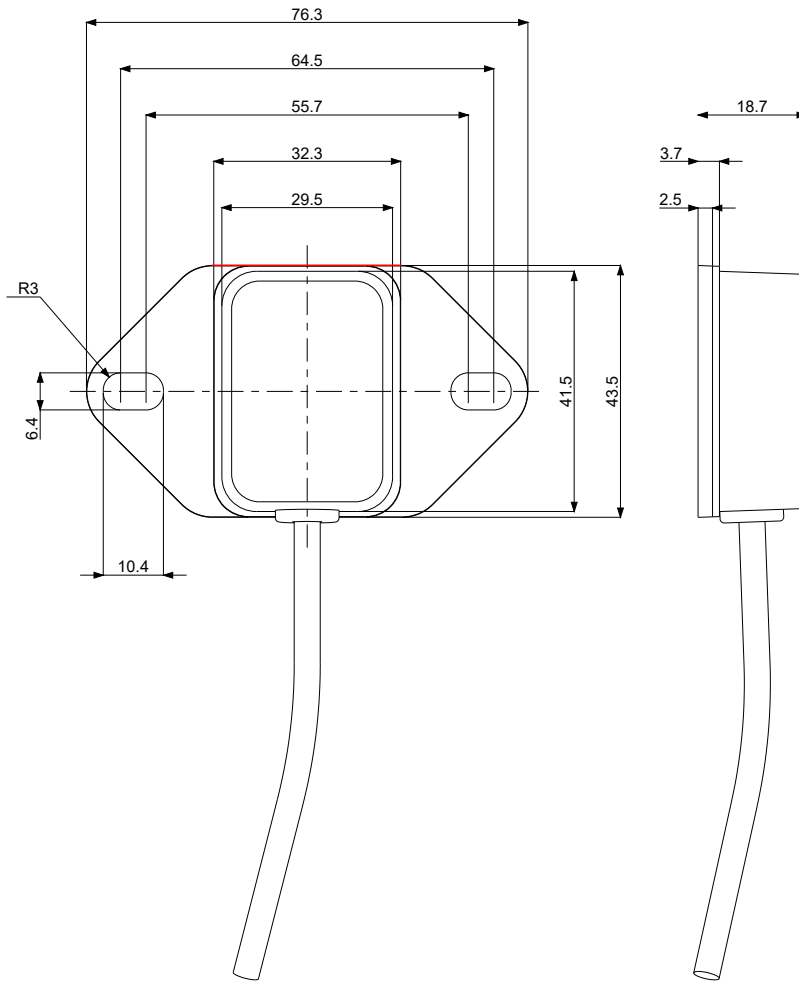

Figure 4: Arrangement of the fastening holes and position of the system edge

6 Connection

6.1 General connection information

The sensor is equipped with a cable with 5-pole round male connector M12 (A-coded) according to IEC 61076-2-101.

A shielded cable must be used. The screen on the power supply must be connected to ground.

6.2 Connector Pin Out

Pin	Signal	Allocation
1	V+	Supply voltage (+24 V)
2	B-OUT	Sensor output B
3	V- / GND	Supply voltage ground / Sensor ground
4	A-OUT	Sensor output A
5	TEACH	Input for zero point adjustment

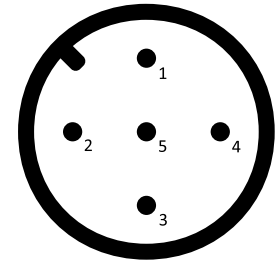

(View from the outside)

Table 2: M12 Plug Connector Pin Out

6.3 Internal circuit

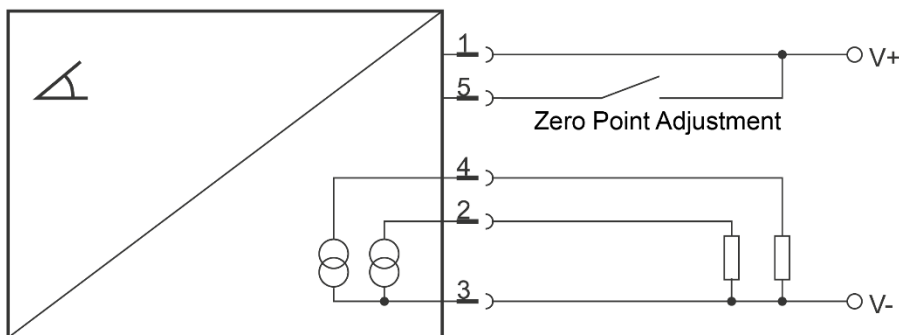

Figure 5: Connection diagram: current interface

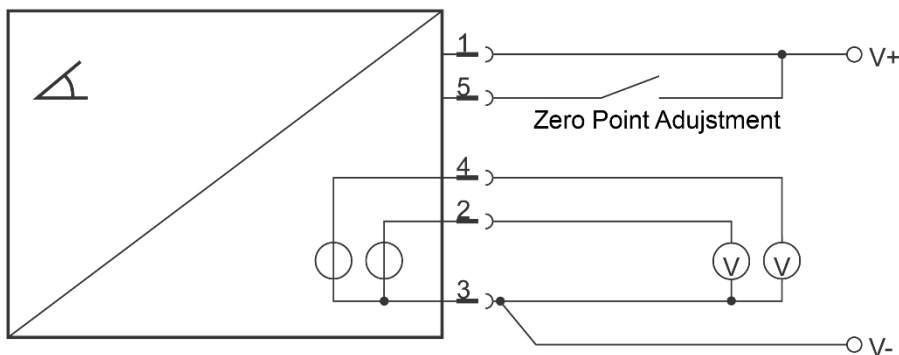

Figure 6: Connection diagram: voltage interface

6.4 Cable length and minimum supply voltage for current interface

For sensors with current output (NExxPxx0-I), the required supply voltage increases by the voltage drop on the connected cable. The highest voltage drop on the cable is produced when the maximum current of 20 mA is flowing through the resistance of the cable (R_L). Here, the resistance of the outgoing and incoming wire must be taken into account (refer to Figure 7).

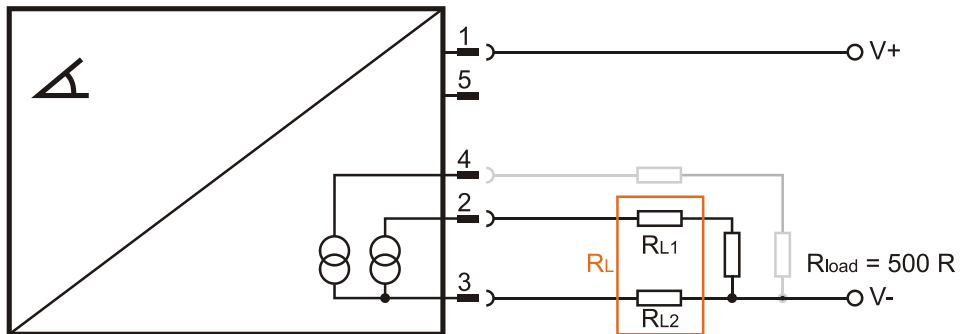

Figure 7: Cable length at current interface

The resistance of the line together with the load resistance used forms a total resistance. Ensure that this total resistance is within the specifications given for the sensor.

7 Functional description

7.1 Default settings

Sensor	Sensor output A	Sensor output B
NExxPxx0-U	X-axis with -90 ... 90° mapped to 0 ... 10 V	Y-axis with -90 ... 90° mapped to 0 ... 10 V
NExxPxx0-I	X-axis with -90 ... 90° mapped to 4 ... 20 mA	Y-axis with -90 ... 90° mapped to 4 ... 20 mA

Table 3: Default output mapping

Parameter	Default value	Description
Filter type low pass filter	2	Filter type critically damped
Cutoff frequency low pass filter	5000	5000 mHz = 5 Hz (-3dB)
Sensor fusion filter	1	Activated
Time of interference suppression	5000	5000 ms = 5 s
Zero point offset	0	Off

Table 4: Default settings of device parameters

The following sensor settings can be made using the ISPA2 starter kit and the ISD Control PC program.

7.2 Axis assignment / Reversal of direction / Range of measuring and output

The analog output of the sensor can be freely set within the permissible measuring range.

NExxPxx0-x has 2 analog outputs A and B, which can be placed arbitrarily on the inclination axes X and Y available in hardware. Both outputs can also be assigned to the same axis. Due to the possible reversal of direction, every conceivable constellation of the output assignment is possible.

7.3 Zero Point Adjustment

The zero point of the sensor can be parameterized. This allows to set the zero position in the installed state of the sensor. This can either be made via the PC program ISD-Control in combination with the sensor programming adapter ISPA2, by the teach adapter TA1 or by means of the teach input. To set the zero point using the teaching input, it has to be connected for a period of at least one second with the supply voltage (V+, pin 1). The current position of the inclination sensor is then set for each output to zero degree angle.

7.4 Low pass filter

The sensor is based on an indirect measurement of the inclination due to the Earth's gravitational field. External accelerations, such as those caused by vibrations, interfere with the function of the sensor due to their principle.

The sensor offers the possibility of making the continuously generated angular value less sensitive to external, disturbing vibrations. Two low pass filters are available in the sensor, which can be selected according to the sensor's area of application.

With the aid of the parameterizable low pass filters (Butterworth or critically damped) eighth order, parasitic oscillations/vibrations up to 0.1 Hz can be suppressed.

Filter	Adjustable frequency range	Applications
Butterworth	0.1 Hz ... 25 Hz	Static inclination measurement with high damping to vibration
Critically damped	0.1 Hz ... 8 Hz	Inclination measurement in applications that requires a certain dynamism, without overshoot at angle changes with good damping

Table 5: Filter selection low pass filter

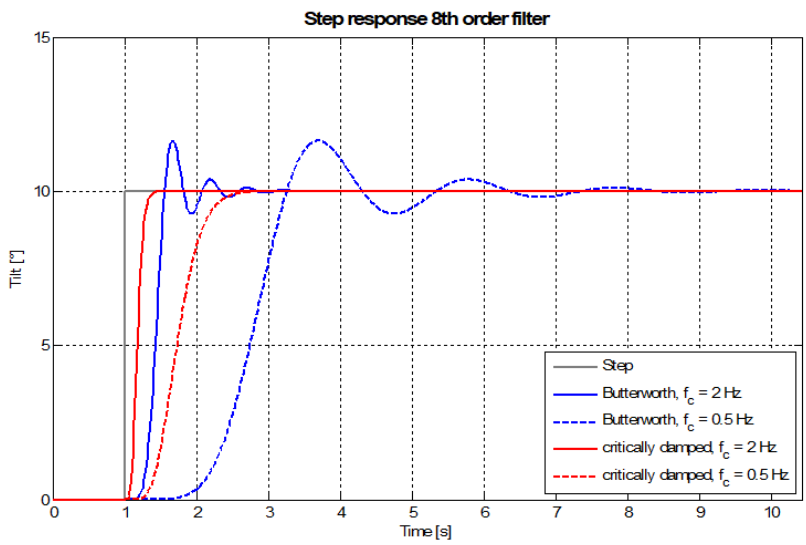

Figure 8: Impulse response of the two low pass filters

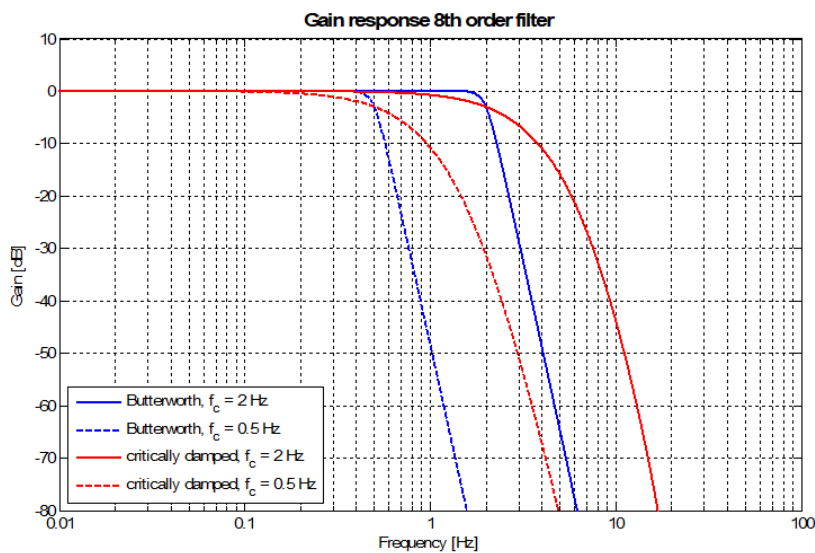

Figure 9: Amplitude response of the two low pass filters

7.5 Sensor fusion filter

External accelerations, such as those caused by vehicles braking or cornering, cannot be reliably suppressed by the low pass filter.

In addition to the earth's gravitational field, the sensor fusion filter uses the rotation rate information of a gyroscope as a measured variable. As a result, external accelerations can be suppressed without the angular information being subject to a noticeable time delay.

The acceleration signal used for the sensor fusion is first preprocessed with the filter described in chapter 7.4 "Low pass filter".

Filter	Adjustable range	Filter
Sensor fusion	100 ms ... 10 s	Dynamic applications, measurements during acceleration/braking or cornering,

Table 6: Filter selection fusion filter

8 Maintenance and Service

8.1 Calibration

Every GEMAC MOTUS® Greenline NE is calibrated by the manufacturer GEMAC Chemnitz GmbH as standard before delivery.

Even the highest quality sensors have to be recalibrated at certain intervals in order to continue to deliver reliable, safe and error-free measurement results. We therefore recommend regular recalibration. This shall be done exclusively by the manufacturer GEMAC Chemnitz GmbH.

8.2 Customer service

8.2.1 Reshipment

Reshipment of the sensor GEMAC MOTUS® Greenline NE for calibration or repairing purposes must be executed in the original packaging or an equivalent packaging. Please indicate a short error description and your phone number for further inquiries.

8.2.2 Support

Please indicate the serial number and the firmware revision of your sensor for technical support.

Manufacturer: GEMAC Chemnitz GmbH

Zwickauer Str. 227

09116 Chemnitz

Tel.: +49 371 3377-0

Fax: +49 371 3377-272

Web: www.gemac-chemnitz.com

E-Mail: info@gemac-chemnitz.de

8.2.3 Warranty and limitation of liability

We will assume a warranty of 24 months for the sensor GEMAC MOTUS® Greenline NE, commencing from the date of delivery. Any repairs which are required during this time and fall under the manufacturer's obligation to give a warranty will be performed free of charge. Any damage resulting from improper use of the device or from exceeding of the specified technical parameters is not covered by the manufacturer's obligation to give a warranty.

GEMAC Chemnitz GmbH will only be liable for consequential damage resulting from use of the product in case of deliberate action or gross negligence on its own part.

The General Terms and Conditions of GEMAC Chemnitz GmbH apply.

9 Sensor configuration

9.1 Inclination sensor programming adapter

Use the separately available inclination sensor programming adapter (ISPA2 - PR-23999-10) to configure the sensor conveniently. The programming adapter is connected via USB to a PC. The connection of the sensors with the programming adapter is realized through the included CAN adapter cable. The sensor is supplied with power through the adapter. No additional voltage supply is necessary.

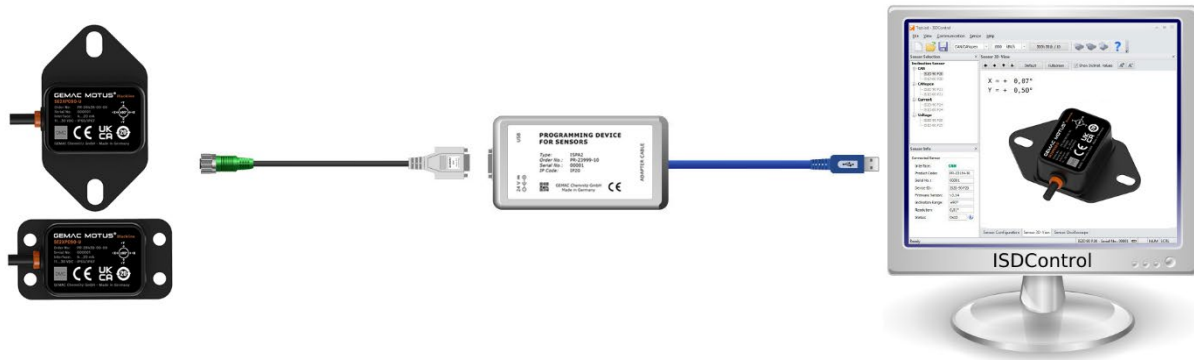

Figure 10: Sensor programming adapter

9.2 PC software ISDControl

The parametrization of all possible values is done with the PC software ISDControl, which is included in all sensor programming adapters. Each configuration can be stored in a file.

Properties:

- comfortable configuration of all parameters of the sensor
- 3D imaging and display of the current angle
- Oscilloscope display of the current angle for perpendicular angle
- Firmware Download option
- Automatic sensor search for unknown communication parameters



Figure 11: PC software

10 Ordering information

Article	Product type	Interface (default)	Hole pattern	Axes/measuring range
PR-28430-00-00	NE1XP360-I	4 ... 20 mA	4-hole	1-dimensional, $\pm 180^\circ$ (360°)
PR-28420-00-00	NE1ZP360-I	4 ... 20 mA	2-hole	1-dimensional, $\pm 180^\circ$ (360°)
PR-28530-00-00	NE1XP360-U	0 ... 10 V	4-hole	1-dimensional, $\pm 180^\circ$ (360°)
PR-28520-00-00	NE1ZP360-U	0 ... 10 V	2-hole	1-dimensional, $\pm 180^\circ$ (360°)
PR-28434-00-00	NE2XP090-I	4 ... 20 mA	4-hole	2-dimensional, $\pm 90^\circ$
PR-28424-00-00	NE2ZP090-I	4 ... 20 mA	2-hole	2-dimensional, $\pm 90^\circ$
PR-28534-00-00	NE2XP090-U	0 ... 10 V	4-hole	2-dimensional, $\pm 90^\circ$
PR-28524-00-00	NE2ZP090-U	0 ... 10 V	2-hole	2-dimensional, $\pm 90^\circ$
PR-23998-00	TA1	Teach-Adapter		
PR-23999-10	ISPA2	Sensor programming adapter (including programming adapter, cables and PC software)		

Table 7: Ordering information