



User manual

GEMAC Motus[®] BLACKLINE Nx analog

Version: 1.0

Date: 13.06.2023



NB2MP360-I
NB2MP360-U
NC2MP360-I
NC2MP360-U

GEMAC Chemnitz GmbH
Zwickauer Strasse 227
09116 Chemnitz, Germany
Germany

Phone: +49 371 3377-0
Fax: +49 371 3377-272
Email: info@gemac-chemnitz.de
Web: www.gemac-chemnitz.com

Revision History

Date	Revision	Change(s)
13.06.2023	1.0	first version

© Copyright 2023 GEMAC Chemnitz GmbH

This document is subject to change without notice.

We constantly work to further develop of our products. We reserve any changes of the scope of delivery in shape, equipment and technology for ourselves. No claims can be made from the details, illustrations and descriptions in this document. Any kind of duplication, reprocessing and translation of this document as well as excerpts from it require the written permission of GEMAC Chemnitz GmbH. All rights according to the copyright remain explicitly reserved for GEMAC Chemnitz GmbH.

Table of contents

1	Safety information	1
1.1	Incoming inspection	1
1.2	Intended use	1
1.3	Incorrect use	1
1.4	Requirements for the qualification of personnel	1
2	Overview.....	2
2.1	Characteristics	2
2.2	Applications.....	2
3	Technical Data.....	3
4	Mounting.....	5
4.1	Fixation.....	5
4.2	Position of mounting holes	5
5	Connection	6
5.1	Connector Pin Out.....	6
5.2	Connection diagram	6
5.3	Cable length and minimum supply voltage for current interface	7
6	Functional description.....	8
6.1	Default settings	8
6.2	Axis assignment / Reversal of direction / Range of measuring and output	8
6.3	Zero Point Adjustment.....	8
6.4	Low pass Filter	9
6.5	Sensor fusion filter	10
6.6	Status LED	10
7	Maintenance and Service	11
7.1	Calibration	11
7.2	Customer service	11
7.2.1	Reshipment.....	11
7.2.2	Support	11
7.2.3	Warranty and limitation of liability	11
8	Sensor configuration.....	12
8.1	Inclination sensor - Programming adapter.....	12
8.2	PC software ISDControl.....	13
8.2.1	Configuration of all values	13
8.2.2	3D view and display of the current angle.....	14

8.2.3	Oscilloscope display of inclination values.....	15
9	Ordering information	16

List of Tables

Table 1: Technical data	4
Table 2: Connector Pin Out	6
Table 3: Default output mapping	8
Table 4: Default settings of device parameters	8
Table 5: Filter selection low pass filter	9
Table 6: Filter selection fusion filter	10
Table 7: Status and Error Display through Status LED	10
Table 8: Order information	16

List of Figures

Figure 1: Orientation of the measuring axis 1-dimensional	4
Figure 2: Orientation of the measuring axes 2-dimensional (factory default settings)	4
Figure 3: Mounting holes (dimensions in mm)	5
Figure 4: Connection diagram: current interface	6
Figure 5: Connection diagram: voltage interface.....	6
Figure 6: Cable length at current interface	7
Figure 7: Impulse response of the two low pass filters.....	9
Figure 8: Amplitude response of the two low pass filters	10
Figure 9: Starter kit	12
Figure 10: Numerical configuration of sensor parameters	13
Figure 11: Graphical configuration of the outputs A and B	14
Figure 12: 3D view and display of the current inclination values	14
Figure 13: Oscilloscope display of the inclination values	15

1 Safety information

1.1 *Incoming inspection*

Unpack the device immediately after you received it and check the entire delivery for completeness. If transport damage is to be assumed, inform the delivery agent within 72 hours and keep the packaging for inspection. The device must only be transported in its original or equivalent packaging.

1.2 *Intended use*

The GEMAC Motus® *BLACKLINE* Nx is a device consisting of an electronic sensor and an integrated evaluation unit. The device is designed to determine inclinations in large-scale fixed installations of industrial automation as well as non-road mobile machinery or means of transport for persons or goods like agricultural and forestry machinery, utility vehicles or crane and hoisting technology.

GEMAC Chemnitz GmbH assumes no liability for losses or damages arising from the use of the product, either directly or indirectly. This applies in particular to use of the product that does not conform to this intended purpose and is not described in this document.

1.3 *Incorrect use*

The GEMAC Motus® *BLACKLINE* Nx is not a safety component according to the EC Machinery Directive (2006/42/EC). It must not be used in explosion hazardous areas. Any use that is not described in section 1.2 "Intended use" is prohibited. Any use of accessories that is not specifically approved by GEMAC Chemnitz GmbH is at your own risk.

1.4 *Requirements for the qualification of personnel*

The personnel who work on and with the GEMAC Motus® *BLACKLINE* Nx must be suitably authorized, trained, and sufficiently qualified. Skilled personnel refers to the following:

- Has received specialist training, which is backed up by additional knowledge and experience according to operation and service of the sensor and the respective application.
- Knows the relevant technical terms and regulations.
- Can appraise the work assigned to them, recognize potential hazards, and take suitable safety precautions.

2 Overview

2.1 Characteristics

- Dynamic inclination sensor
 - independent of the local gravity field through 3D measurement
- Easy to handle parametrization with GEMAC programming tools
 - configurable filter for vibration suppression
- High sampling rate and bandwidth
- High resolution (0.01°)
- High static accuracy independent of sensors orientation, model-dependent up to $\pm 0.1^\circ$
 - including compensated cross sensitivity
- Dynamic accuracy model-dependent up to $\pm 0.25^\circ$
 - including compensated cross sensitivity
- Comfortable current and voltage interface
- UV-resistant, impact-resistant plastic housing
- Suitable for industrial use:
 - Temperature range: -40°C to $+85^\circ\text{C}$
 - Degree of protection: IP65/67 and IP6K9K

The sensor is factory calibrated in all measuring axes to ensure high accuracy.

The compact and robust design makes the sensors a suitable angle measurement device in rough surroundings for different applications in industry and vehicle technology.

2.2 Applications

- Agricultural and forestry machinery
- Construction machinery
- Crane and hoisting technology

3 Technical Data

General parameters ¹	NB2MP360-x		NC2MP360-x	
Measurement range	±90° (perpendicular angle) or ±180° (roll angle) ²			
Resolution	0,01°			
Static accuracy (including cross sensitivity)	typical	maximum	typical	maximum
	±0.3°	±0.5°	±0.1°	±0.15°
Dynamic accuracy (including cross sensitivity)	typ. ±0.5°			
Duration of suppression of external accelerations (configurable)	100 – 10000 ms			
Temperature coefficient (zero point)	typ. ±0.01 °/K		typ. ±0.003 °/K	
Sampling rate	200 Hz			
Operating temperature	-40 °C to +85 °C ³			
Characteristics				
Current interface	Nx2MP360-I		Nx2MP360-U	
	freely adjustable output in the range 0 ... 24 mA (factory default: 4 ... 20 mA) max. load resistance 650 Ω (up to 20 mA) max. load resistance 550 Ω (up to 24 mA)		freely adjustable output in the range 0 ... 10 V	
Functions	Teach input for zero point adjustment when installed. Full scale value limit, Axis direction and assignment of the outputs are adjustable. Digital low pass filter (critically damped or Butterworth, 8 th order)			
Electrical parameters				
Supply voltage	10 ... 36 VDC			
Current consumption	approx. 30 mA @ 24 V (for Nx2MP360-I depending on the output current up to 70 mA @ 24 V)			
Mechanical parameters				
Connection	Sensor connector 5-pole M12 (male)			
Degree of protection	IP65/67 - IP6K9K ⁴			
Dimensions / Weight	109 mm x 66 mm x 30 mm / approx. 200 g			
Reliability according to EN ISO 13849-1 ⁵				
	NB2MP360-I	NB2MP360-U	NC2MP360-I	NC2MP360-U
MTTF	369 years	394 years	367 years	362 years
MTTFd	771 years	767 years	692 years	684 years

1 All indicated angle accuracies are valid after a running time of 10 minutes at 25 °C, absolute calibration accuracy (at 25 °C): ±0.05°.

2 Up to 2 measuring axes with configurable orientation

3 The maximum temperature range of 85 °C is only valid for the Sx2MP360-I sensors with a minimum load resistance of 250 Ω and a maximum output current of 20 mA.

4 Only in connection with article no. 1404066 from Phoenix Contact GmbH and a tightening torque of 0.4 Nm.

5 This product is a standard product and no safety part in accordance with the machinery directive. The calculation is based on an average environment temperature of 40 °C and a usage of 8760 h/a.

CE conformity	
EC Directives	
RL 2014/30/EU	Harmonisation of the laws of the Member States relating to electromagnetic compatibility
RL 2011/65/EU	Restriction of the use of certain hazardous substances in electrical and electronic equipment
Harmonized standards	
DIN EN ISO 13766-1:2019-04 ⁶	Earth-moving machinery and construction machinery - Electromagnetic compatibility of machinery with internal electrical system - Part 1: General EMC requirements under typical EMC environmental conditions (ISO 13766-1:2018)
DIN EN IEC 63000:2019-05	Technical documentation for the assessment of electrical and electronic products with respect to the restriction of hazardous substances

Table 1: Technical data



Figure 1: Orientation of the measuring axis 1-dimensional

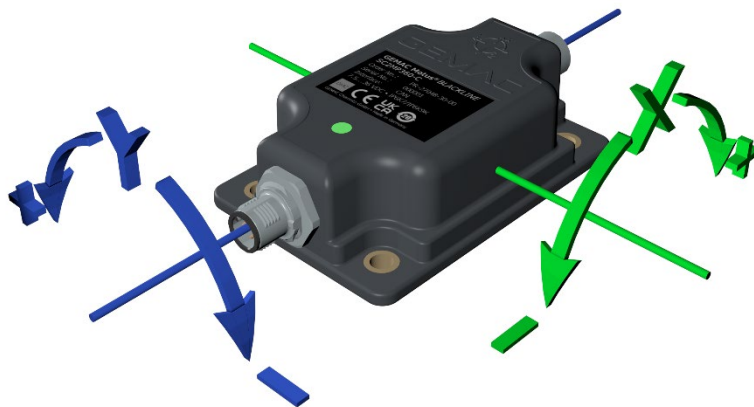

Figure 2: Orientation of the measuring axes 2-dimensional (factory default settings)

⁶ A voltage limitation of the load-dump pulse of 58 V is assumed (see Figure 9. ISO 16750-2:2012).

4 Mounting

4.1 Fixation

The Sensor has to be screwed in place by using 4 hexagon socket screws M5 according to DIN 912 A2 and 4 hexagon nuts M5 according to DIN 934 with a torque of 3 Nm in a manner, that one full thread of the screw is overlapping minimum.

4.2 Position of mounting holes

Holes to mount the sensor (Figure 3) are situated in the base plate of the sensor.

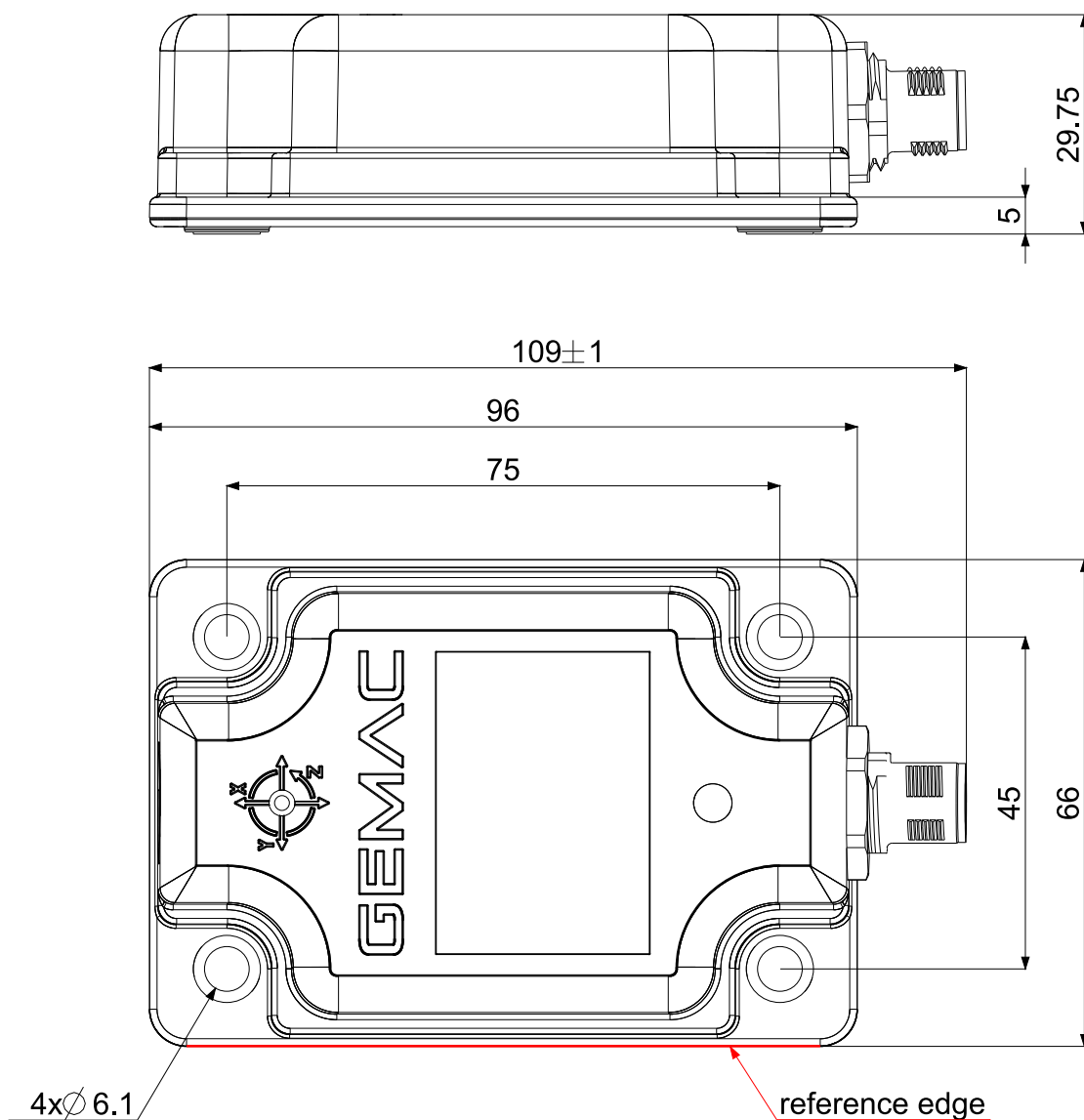

Figure 3: Mounting holes (dimensions in mm)

5 Connection

5.1 Connector Pin Out

The sensors are equipped with a common 5-pole round plug M12 (A-coded).

PIN	Signal	Allocation
1	V+	Supply voltage (+24 V)
2	B-OUT	Sensor output B
3	V- / GND	Supply voltage ground / Sensor ground
4	A-OUT	Sensor output A
5	TEACH	Input for zero point adjustment

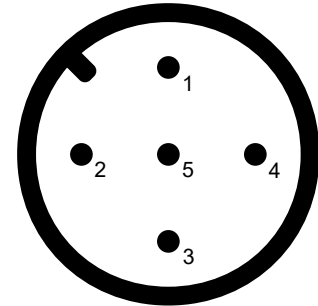

(View from outside)

Table 2: Connector Pin Out

5.2 Connection diagram

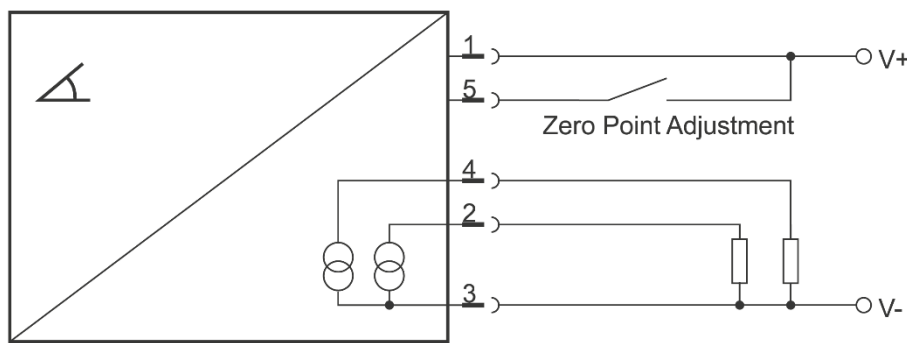

Figure 4: Connection diagram: current interface

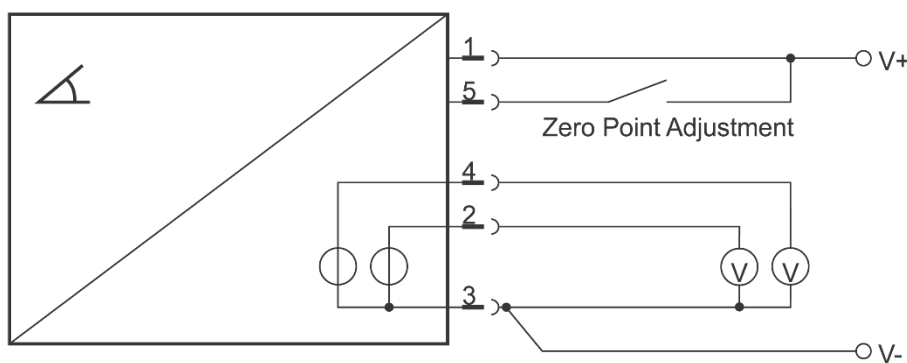

Figure 5: Connection diagram: voltage interface

5.3 Cable length and minimum supply voltage for current interface

For sensors with current output (Nx2MP360-I), the required supply voltage increases by the voltage drop on the connected cable. The highest voltage drop on the cable is produced when the maximum current of 20 mA is flowing through the resistance of the cable (R_L). Here, the resistance of the outgoing and incoming wire must be taken into account (refer to Figure 6).

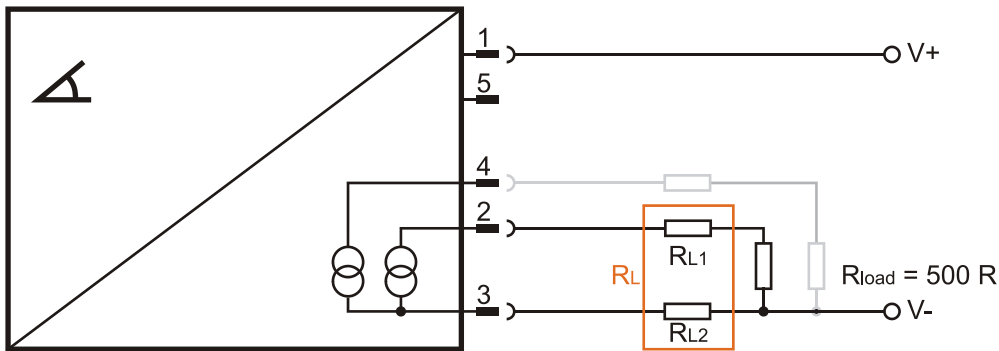

Figure 6: Cable length at current interface

The resistance of the line together with the load resistance used forms a total resistance. Ensure that this total resistance is within the specifications given for the sensor.

6 Functional description

6.1 Default settings

Sensor	Sensor output A	Sensor output B
Nx2MP360-U	X-axis with -90 ... 90° mapped to 0 ... 10 V	Y-axis with -90 ... 90° mapped to 0 ... 10 V
Nx2MP360-I	X-axis with -90 ... 90° mapped to 4 ... 20 mA	Y-axis with -90 ... 90° mapped to 4 ... 20 mA

Table 3: Default output mapping

Parameter	Default value	Description
Filter type low pass filter	2	Filter type critically damped
Cutoff frequency low pass filter	5000	5000 mHz = 5 Hz (-3dB)
Sensor fusion filter	1	Activated
Time of interference suppression	5000	5000 ms = 5 s
Zero point offset	0	Off

Table 4: Default settings of device parameters

The following sensor settings can be made using the ISPA2 starter kit and the ISD Control PC program.

6.2 Axis assignment / Reversal of direction / Range of measuring and output

The analog output of the sensor can be freely set within the permissible measuring range.

Nx2MP360-x has 2 analog outputs A and B, which can be placed arbitrarily on the inclination axes X and Y available in hardware. Both outputs can also be assigned to the same axis. Due to the possible reversal of direction, every conceivable constellation of the output assignment is possible.

6.3 Zero Point Adjustment

The zero point of the sensor can be parameterized. This allows to set the zero position in the installed state of the sensor. This can either be made via the PC program ISD-Control in combination with the starter-kit ISPA2, by the teach adapter TA1 or by means of the teach input. To set the zero point using the teaching input, it has to be connected for a period of at least one second with the supply voltage (V+, pin 1). The current position of the inclination sensor is then set for each output to zero degree angle. The sensor will confirm this by turning off the Status LED for the duration of one second. To reset the zero point to factory defaults, the teaching input has to be connected for the duration of three additional seconds to the supply voltage. The sensor will indicate this by turning off the Status LED also for three seconds.

6.4 Low pass Filter

The sensor is based on an indirect measurement of the inclination due to the earth's gravity field. External accelerations, such as those that can occur due to vibrations, interfere with the function of the sensor.

The sensor offers the possibility of making the continuously arising angle value less sensitive to external, disruptive vibrations. Two low-pass filters are available in the sensor, which can be selected according to the area of application of the sensor.

With the aid of the parameterizable low pass filter (Butterworth or critically damped) of the eighth order, parasitic oscillations / vibrations up to 0.1 Hz can be suppressed.

Filter	Adjustable Band	Applications
Butterworth	0.1 Hz ... 25 Hz	Static inclination measurement with high damping to vibration
Critically damped	0.1 Hz ... 8 Hz	Inclination measurement in applications that requires a certain dynamism, without overshoot at angle changes with good damping

Table 5: Filter selection low pass filter

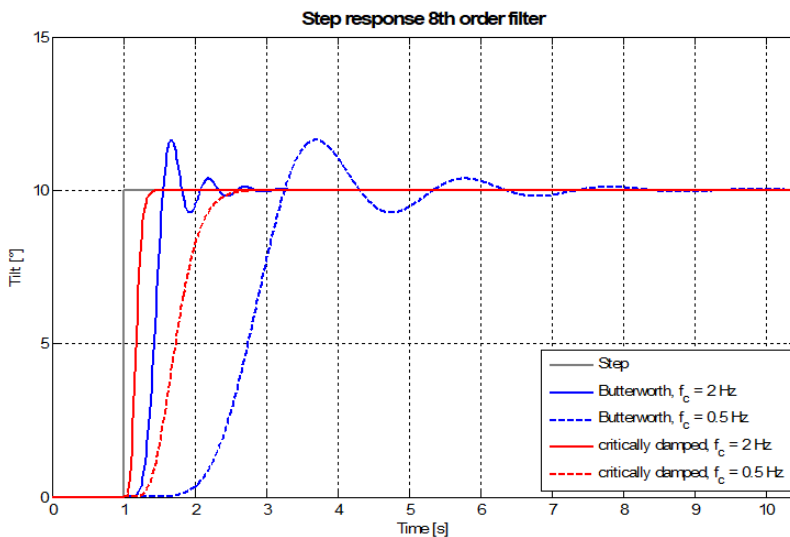

Figure 7: Impulse response of the two low pass filters

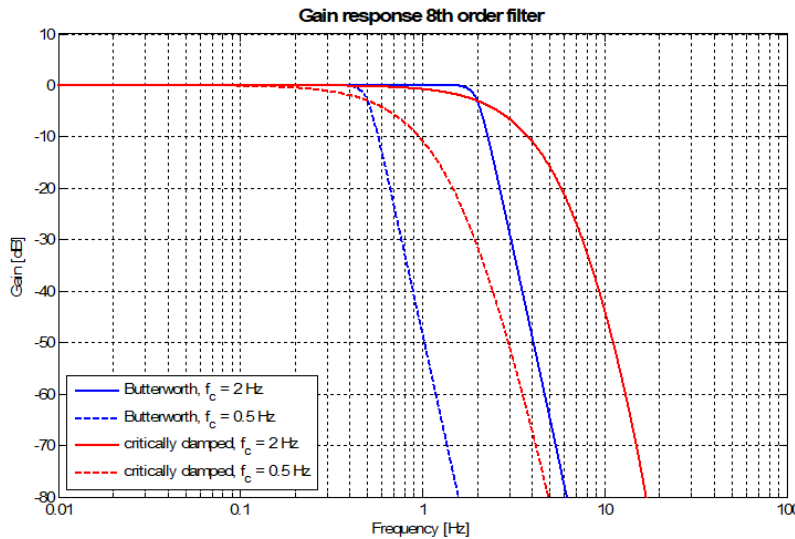

Figure 8: Amplitude response of the two low pass filters

6.5 Sensor fusion filter

External accelerations that occur, for example, when vehicles brake or corner, cannot be reliably suppressed by the low pass filter.

In addition to the earth's gravitational field, the sensor fusion filter uses the rotation rate information of a gyroscope as a measured variable. Thus, external accelerations can be suppressed without the angle information being subject to a noticeable time delay.

The acceleration signal used for the sensor fusion is first preprocessed with the filter described in chapter 6.4 "Low pass Filter".

Filter	Adjustable Band	Applications
Sensor fusion	100 ms...10 s	Dynamic applications, measurements during acceleration/braking or cornering, measurement without time delay of the signal

Table 6: Filter selection fusion filter

6.6 Status LED

The integrated two-color Status LED signals the recent device state. The color of the LED distinguishes the different device states as shown in Table 7.

Status LED	Description
Off	No power supply or teach confirmation
Green	The device is in working condition
Red	Current interface: one or both outputs in open circuit condition or wrong connected Voltage interface: one or both outputs in short circuit condition or wrong connected

Table 7: Status and Error Display through Status LED

7 Maintenance and Service

7.1 Calibration

Every GEMAC Motus® *BLACKLINE* Nx is calibrated by the manufacturer GEMAC Chemnitz GmbH as standard before delivery.

Even the highest quality sensors have to be recalibrated at certain intervals in order to continue to deliver reliable, safe and error-free measurement results. We therefore recommend regular recalibration. This shall be done exclusively by the manufacturer GEMAC GmbH.

7.2 Customer service

7.2.1 Reshipment

Reshipment of the sensor GEMAC Motus® *BLACKLINE* Nx for calibration or repairing purposes must be executed in the original packaging or an equivalent packaging. Please indicate a short error description and your phone number for further inquiries.

7.2.2 Support

Please indicate the serial number and the firmware revision of your sensor for technical support.

Manufacturer: GEMAC Chemnitz GmbH
Zwickauer Str. 227
09116 Chemnitz / Germany
Phone: +49 371 3377-0
Fax: +49 371 3377-272
Web: www.gemac-chemnitz.com
Mail: info@gemac-chemnitz.de

7.2.3 Warranty and limitation of liability

We will assume a warranty of 24 months for the sensor GEMAC Motus® *BLACKLINE* Nx, commencing from the date of delivery. Any repairs which are required during this time and fall under the manufacturer's obligation to give a warranty will be performed free of charge. Any damage resulting from improper use of the device or from exceeding of the specified technical parameters is not covered by the manufacturer's obligation to give a warranty.

GEMAC Chemnitz GmbH will only be liable for consequential damage resulting from use of the product in case of deliberate action or gross negligence on its own part.

The General Terms and Conditions of GEMAC Chemnitz GmbH apply.

8 Sensor configuration

8.1 Inclination sensor - Programming adapter

Use the separately available programming adapter (starter kit ISPA2 - PR-23999-10) to configure the sensor conveniently. The programming adapter is connected via USB to a PC. The connection of the sensors with the programming adapter is realized through the included CAN adapter cable. The sensor is supplied with power through the adapter. No additional voltage supply is necessary.

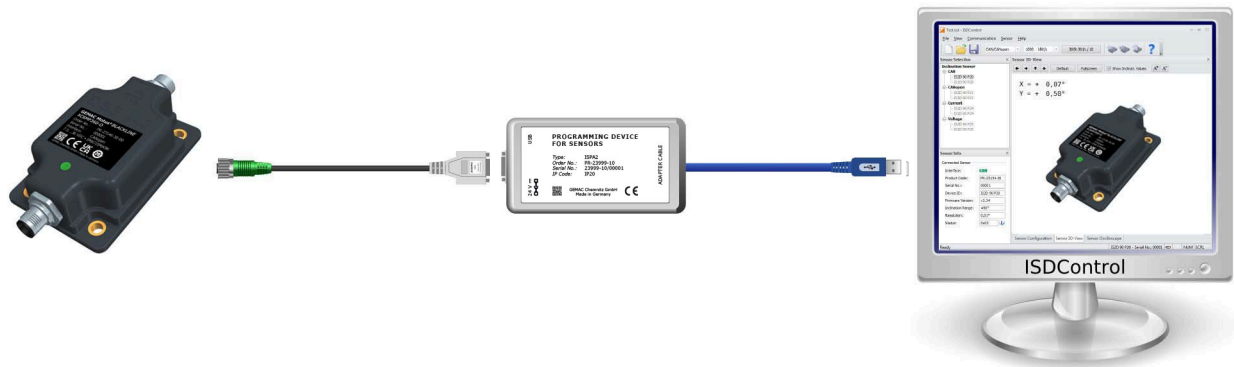

Figure 9: Starter kit

8.2 PC software ISDControl

The parametrization of all possible values is done with the PC software ISDControl, which is included in all starter kits. Each configuration can be stored in a file.

8.2.1 Configuration of all values

For all inclination sensors, the adjustment of the parameters can be done either numerically or graphically. (refer to Figure 10 and Figure 11).

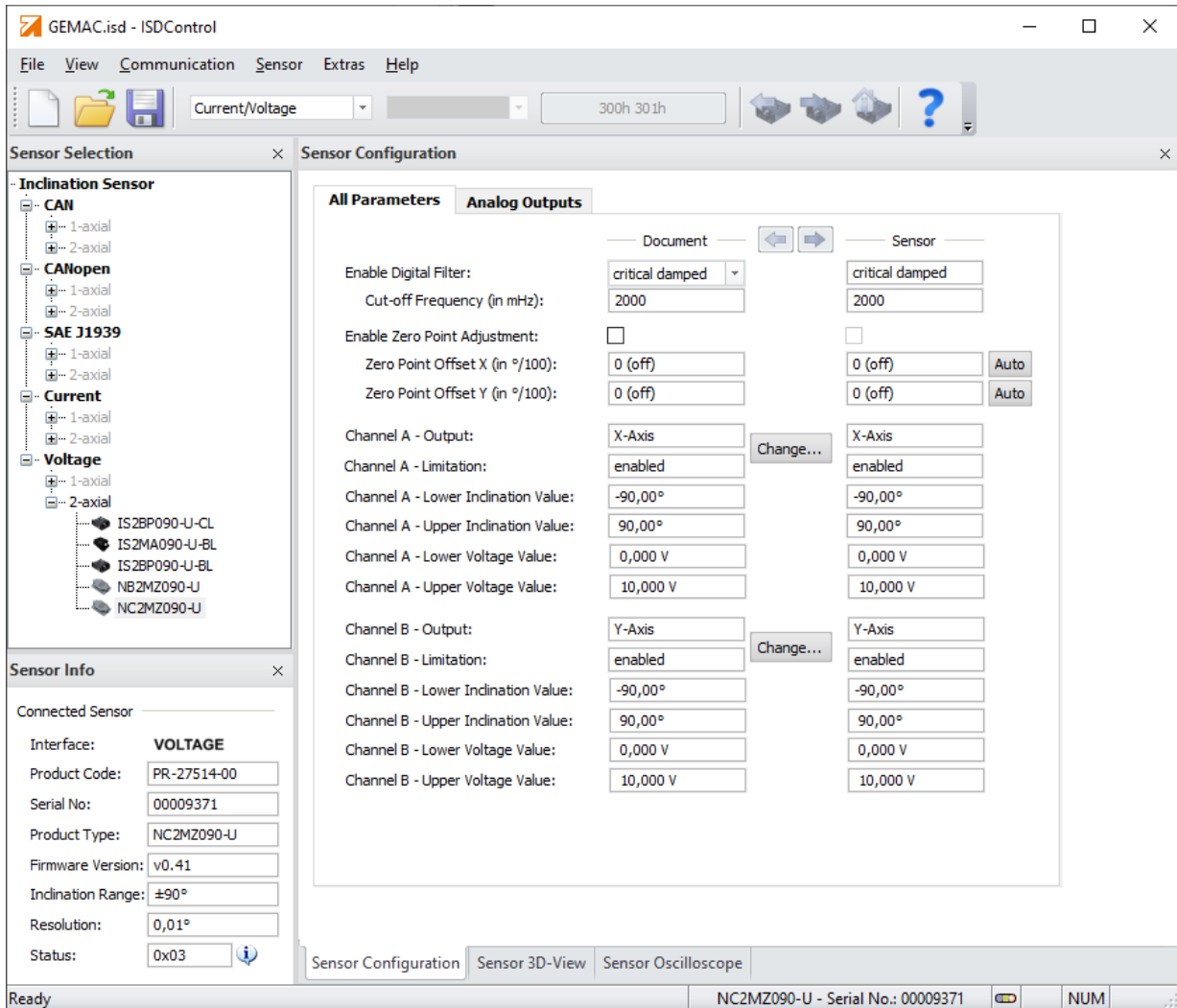

Figure 10: Numerical configuration of sensor parameters

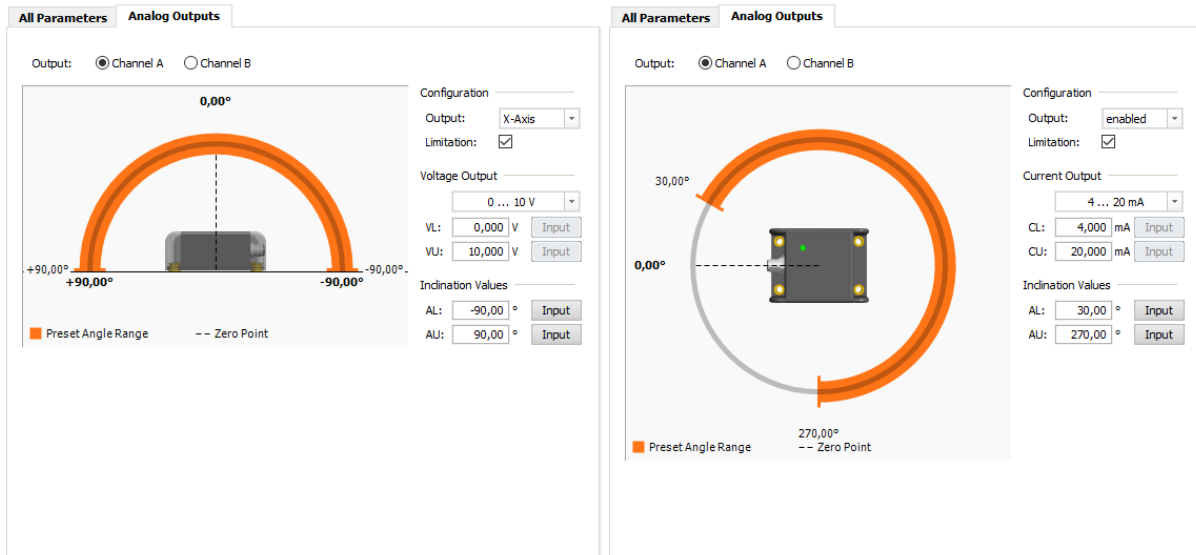

Figure 11: Graphical configuration of the outputs A and B

8.2.2 3D view and display of the current angle

Using the programs integrated 3D view, the position of the sensor in space can be visualized.

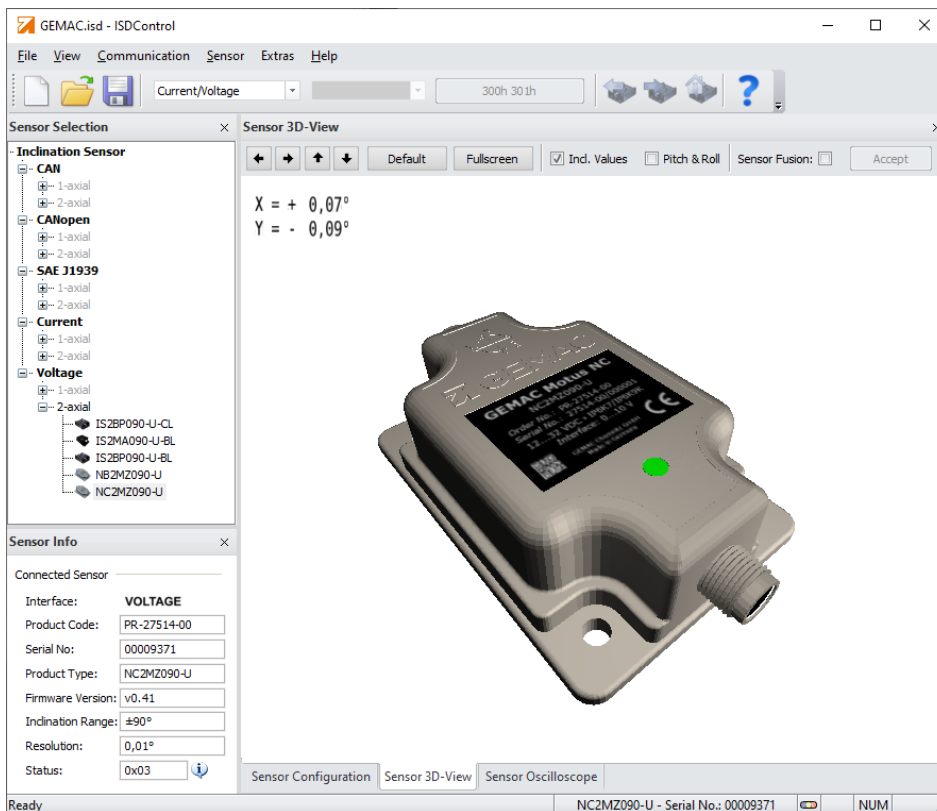

Figure 12: 3D view and display of the current inclination values

8.2.3 Oscilloscope display of inclination values

In the oscilloscope display, the influence of the adjustable low pass filter and sensor fusion filter can be controlled directly. Time base of the view, and amplitude and offset can be set analog to the operation of an oscilloscope.

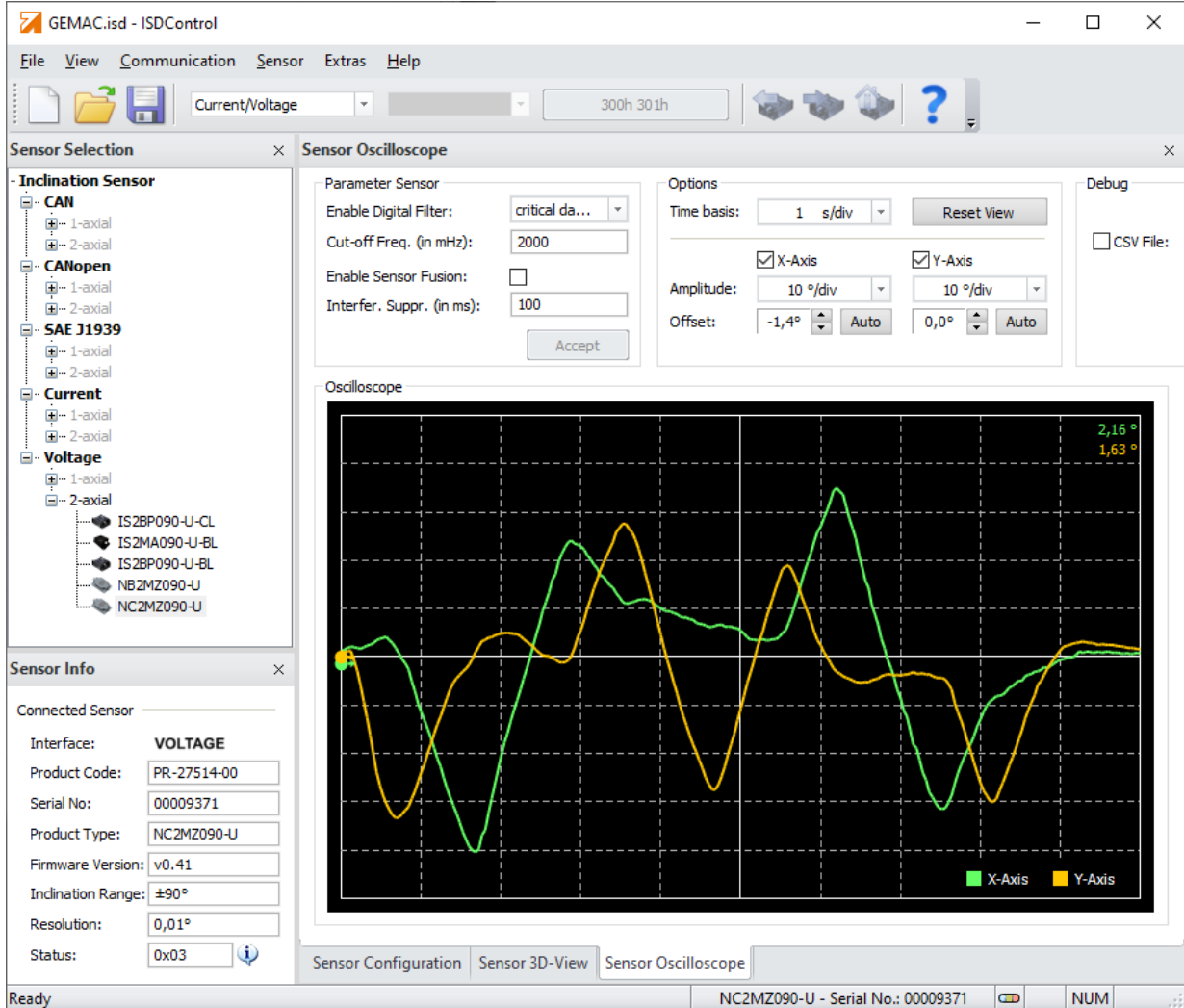

Figure 13: Oscilloscope display of the inclination values

9 Ordering information

Article	Product	Interface (default)	Axes/measuring range
PR-26444-00-00	NB2MP360-I	4 ... 20 mA	2-dimensional, $\pm 360^\circ$
PR-26544-00-00	NB2MP360-U	0 ... 10 V	2-dimensional, $\pm 360^\circ$
PR-27444-00-00	NC2MP360-I	4 ... 20 mA	2-dimensional, $\pm 360^\circ$
PR-27544-00-00	NC2MP360-U	0 ... 10 V	2-dimensional, $\pm 360^\circ$
PR-23998-00	TA1	Teach adapter	
PR-23999-10	ISPA2	Inclination sensor programming adapter (Starter kit including programming adapter, cables and PC software)	

Table 8: Order information